



MULTIMEDIA

OLYMPIAN HIGH SCHOOL

<http://www.vectordiary.com/illustrator/create-a-snazzy-retro-badge-tutorial/>

Illustrator Tutorial: Create A Snazzy Retro Badge

By [Vinay Bhat](#)



This tutorial will help you create a **vector retro badge** or emblem. Particularly, in this year, the number of websites using these as attention grabbers is increasing, and it is being touted as a design trend that is not very likely to cease anytime soon. So, it becomes very important as a designer to know how to create these badges. Having these in your arsenal is sure to grab some eyeballs! So what are we waiting for, let's get started.

Note: The Ctrl equivalent for Macintosh computers is Command or Cmd. And the Alt equivalent is the Option key.

1. Alright, let's start off with the usual drill. Create a new document. I have started with an artboard of width and height of 1000px. Also, it helps to have Smart Guides turned on. They are very helpful for aligning elements on the artboard. If you haven't already enabled them, hit Ctrl + U or go to View > Smart Guides. Now, with the Ellipse Tool (L) hold the option key and click anywhere on the artboard and in the pop up window, hit 280px in both width and height.



MULTIMEDIA

OLYMPIAN HIGH SCHOOL

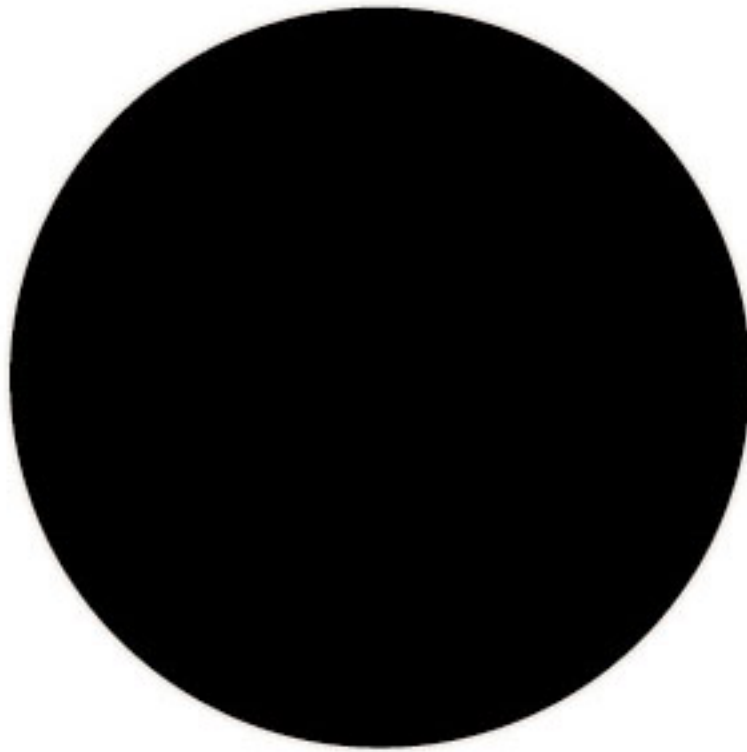

Ellipse

Options

Width:

Height:



MULTIMEDIA

OLYMPIAN HIGH SCHOOL

2. Now, switch to arrow tool, click on the circle to select it and then change its Fill to white. Since this tutorial will be dealing a lot with different effects and such, it helps to have your Appearance Panel open. Hit Shift + F6 or alternatively, go to Window > Appearance. Add a stroke to the circle and change its weight to 2pt. You can use the Appearance panel to make these changes, as shown in the image.

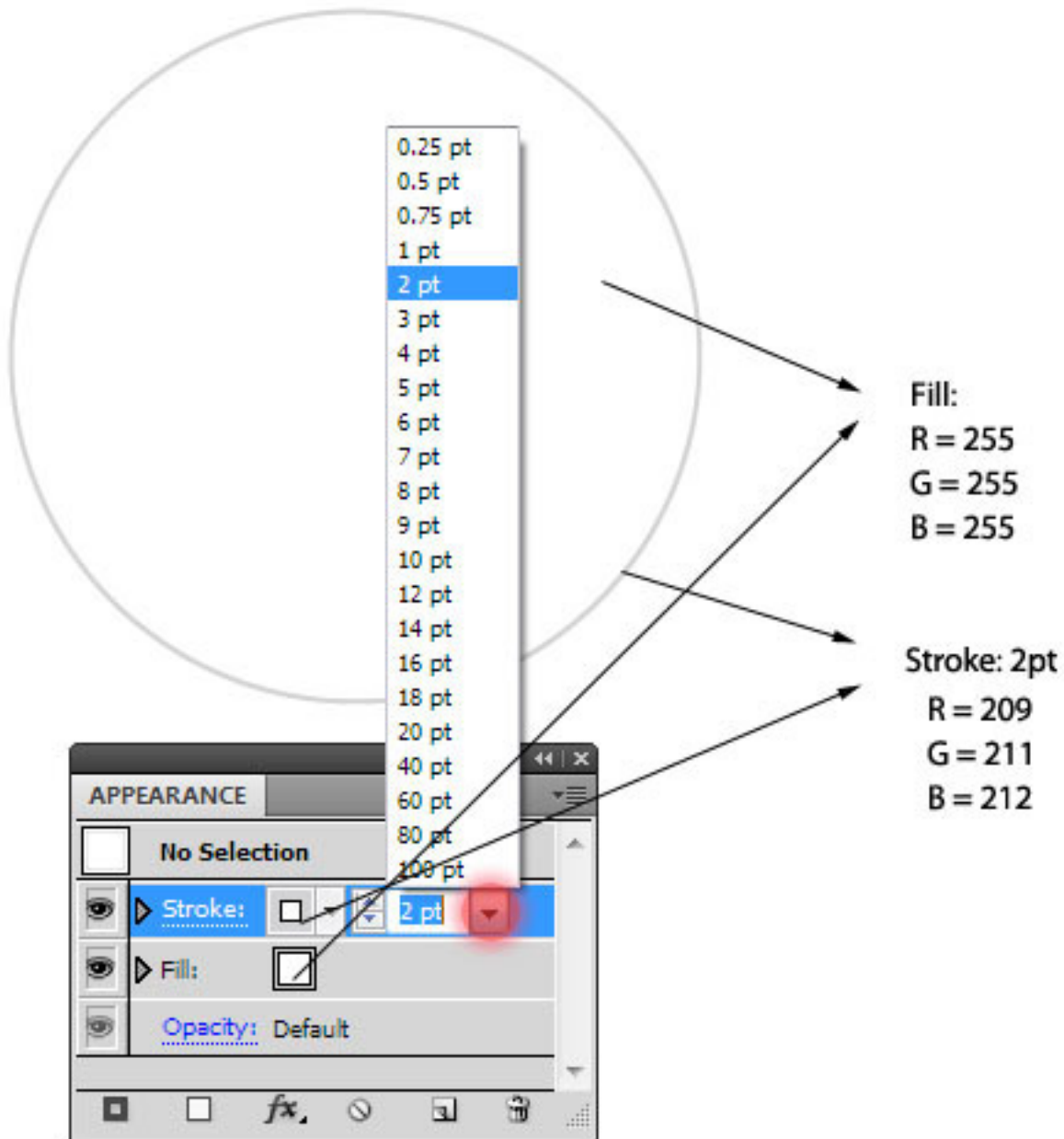



MULTIMEDIA

OLYMPIAN HIGH SCHOOL

3. With the circle selected, go to the Appearance Panel and hit the first button from the bottom-left to add a new stroke. Click on the word "Stroke" to change its settings. Now add in the values as shown in the image. Make sure that the new stroke is below the previous stroke. If it isn't then drag it below the previous stroke.

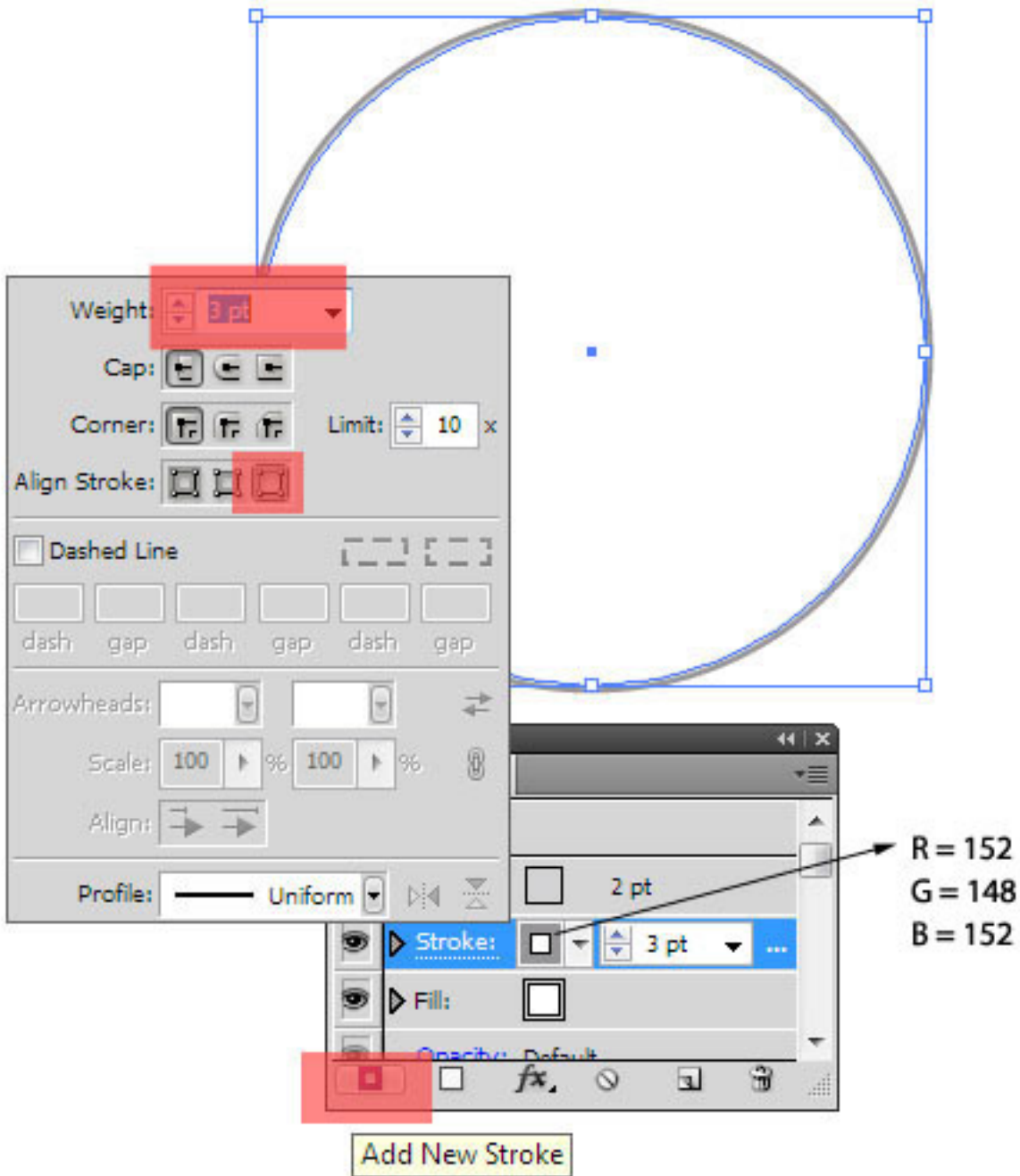



MULTIMEDIA

OLYMPIAN HIGH SCHOOL

4. With the circle selected go to Effect > Distort and Transform > Zig Zag and enter the values as shown in the image.

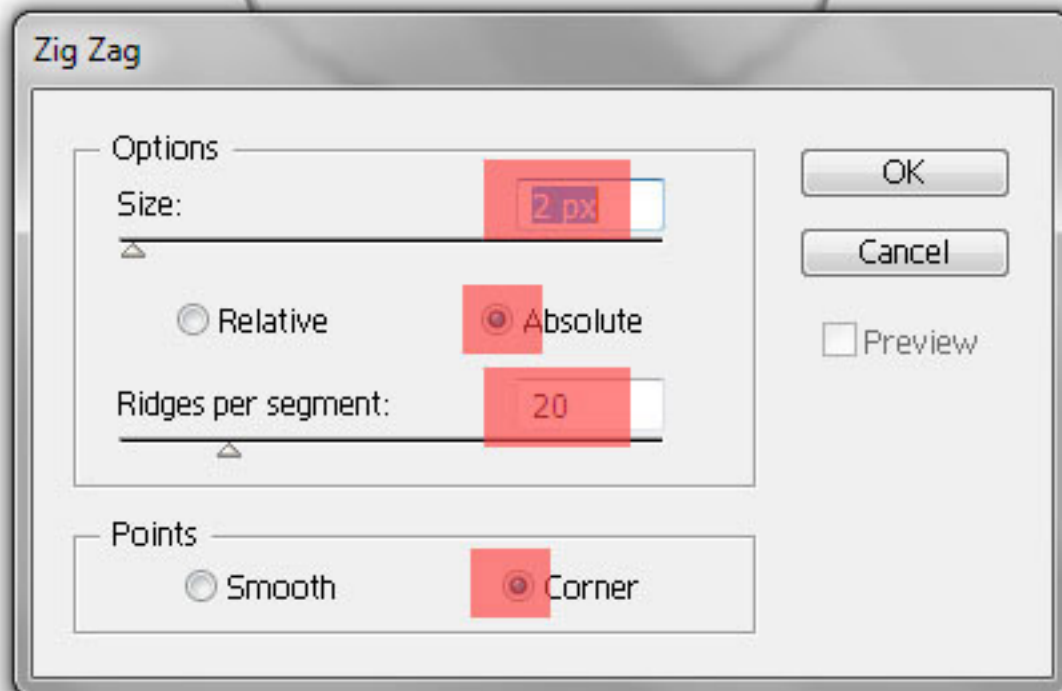



5. Let's round off the spikes. Again, with the circle selected, go to Effect > Stylize > Round Corners and enter a radius of 2 px. You would have observed in the previous step that there was an option to "Smooth" the points. Yes, that could have been done, but, having manual control on how smooth you want it to be is much better, which you could only achieve with this step.

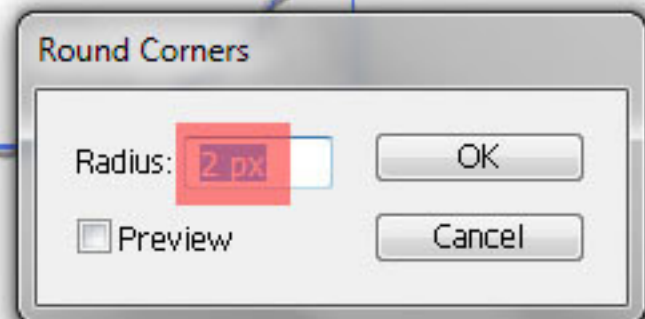
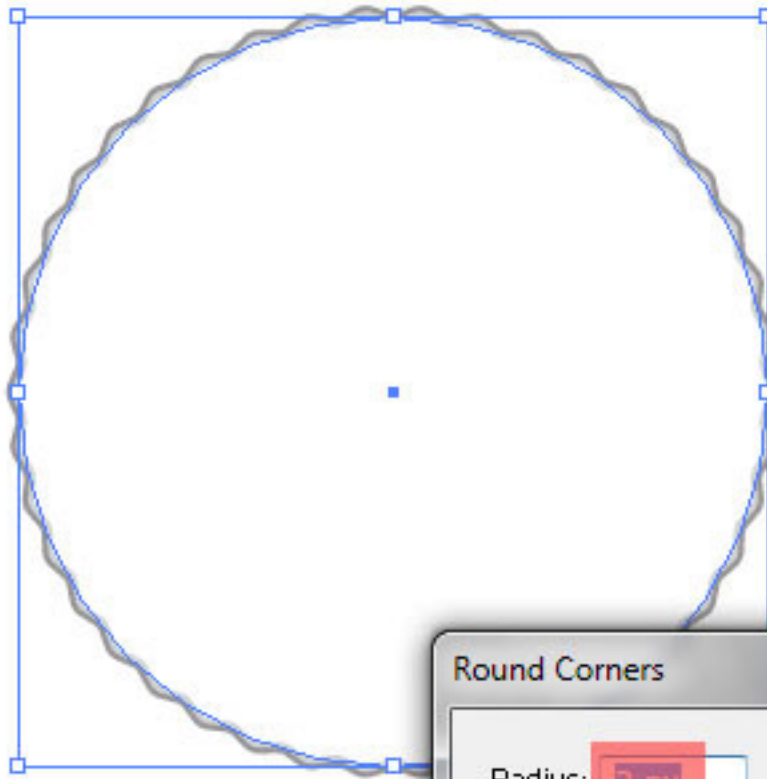



MULTIMEDIA

OLYMPIAN HIGH SCHOOL

6. Copy the circle by hitting Ctrl + C and paste it in front by hitting Ctrl + F. Now, select the new circle and change its dimensions by using the toolbar on the top (You can view it only after selecting any element.) Also, don't forget to click on the link so as to make sure that the dimensions are equal and proportional.

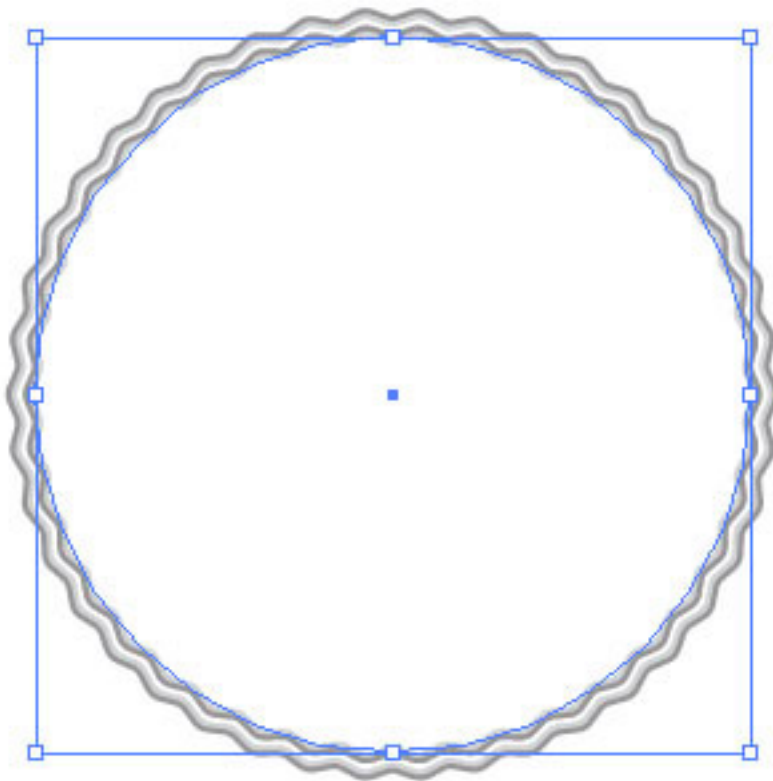
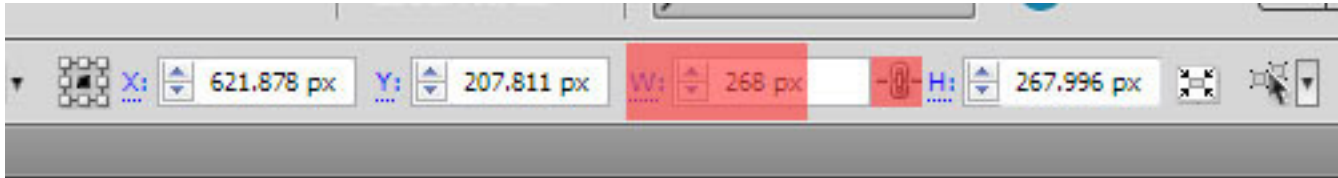



MULTIMEDIA

OLYMPIAN HIGH SCHOOL

7. Let's modify this new new circle. With the Appearance Panel, select both the "Stroke" and delete them using the trash bin icon below as shown in the image.

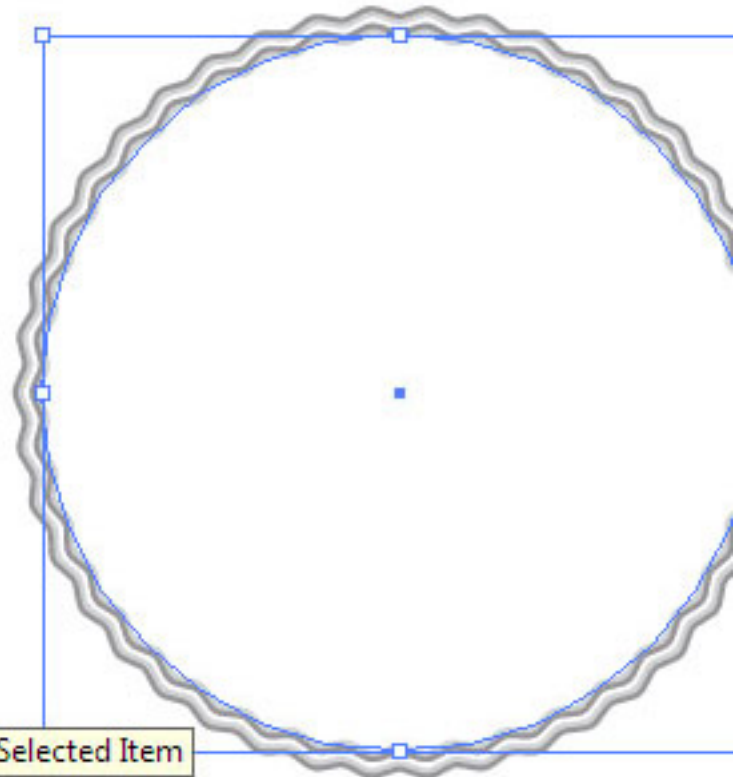
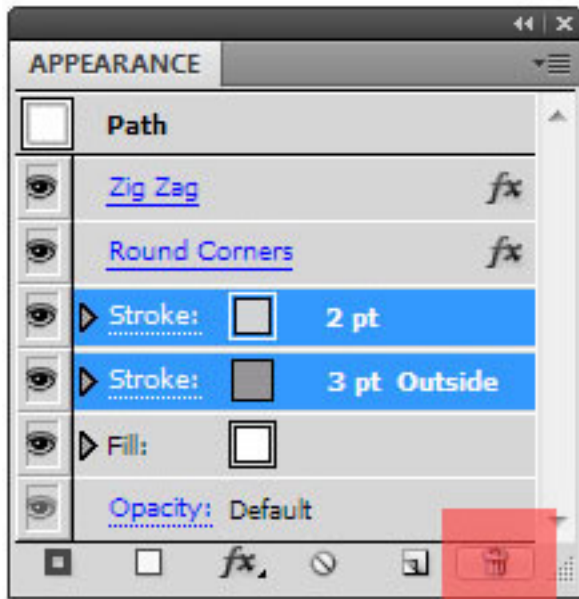



MULTIMEDIA

OLYMPIAN HIGH SCHOOL

8. Let's give this new circle a different color. With it being selected, either use the Fill Square from the Tool bar or you can directly change the Fill using the Appearance Panel as shown in the image below. The color values are also given in the image for reference.

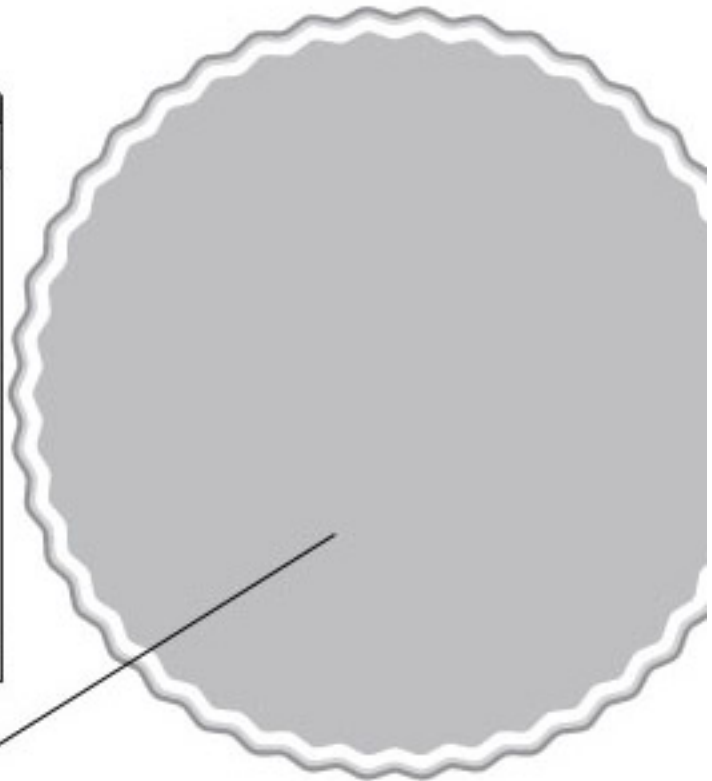
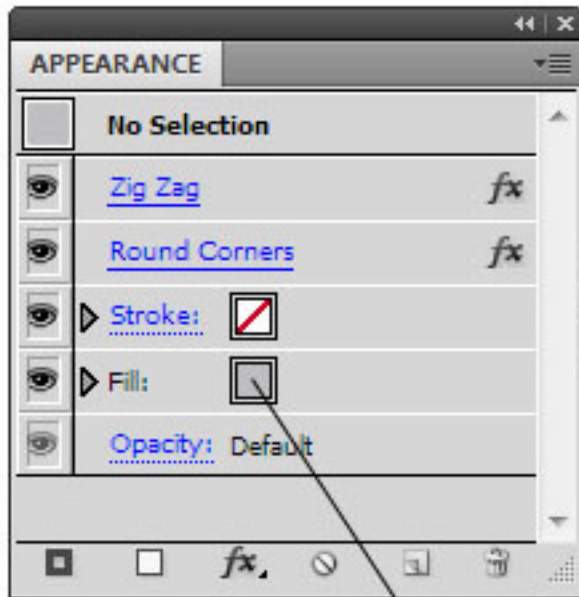

R = 190
G = 191
B = 193



MULTIMEDIA

OLYMPIAN HIGH SCHOOL

9. In the Appearance Panel, hit on the “New Fill” button to add a new fill. Also navigate to the Swatch Libraries Menu by clicking on the down pointing arrow next to the fill content (as shown in image). This would bring out a pop out menu. Click on the bottom-left first icon to go to “Swatch Libraries Menu”. From there, choose the “Diamond” texture by going to Patterns > Basic Graphics > Basic Graphic_Textures.

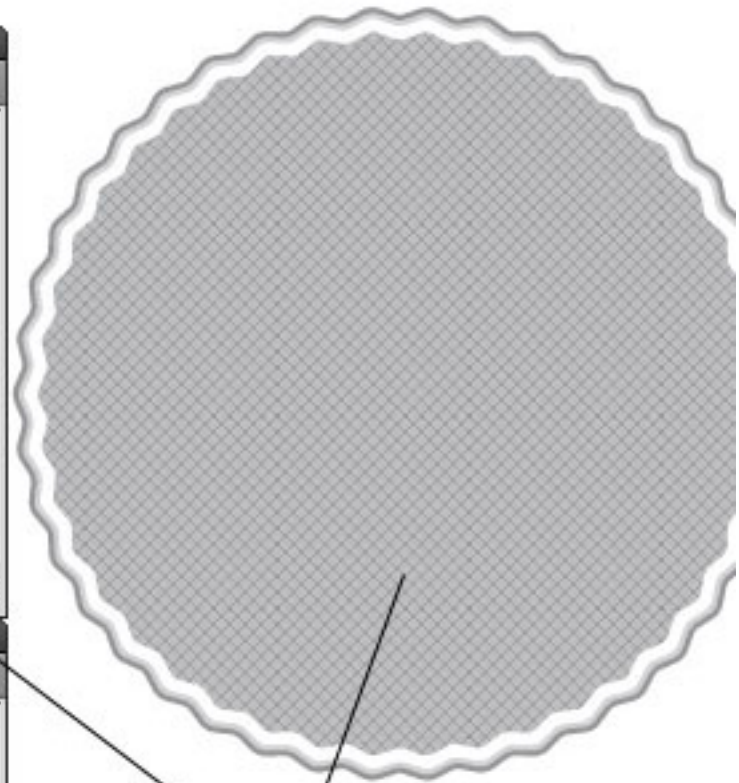
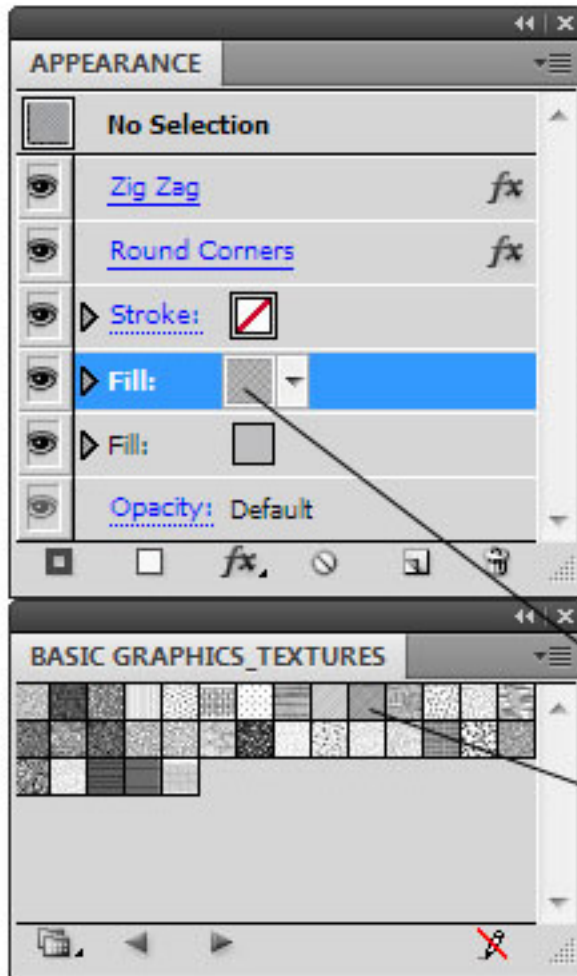

'Diamond' texture
Patterns > Basic Graphics
> Basic Graphic_Textures



MULTIMEDIA

OLYMPIAN HIGH SCHOOL

10. Now, set this new fill on overlay with 48% opacity. You can do this by clicking on the right pointing arrow next to the word "Fill". Then with this Fill selected go to Effect > Texture > Grain and set both, Intensity and Contrast to 100.

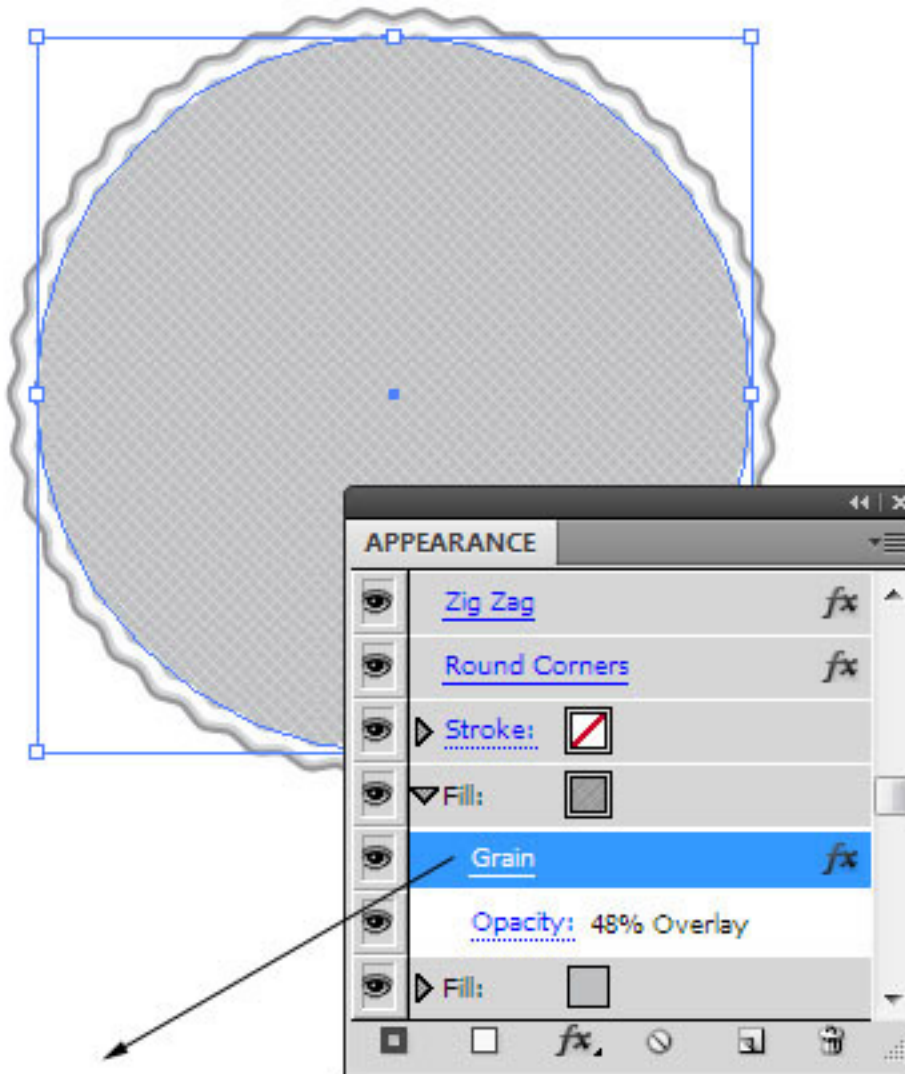

Intensity : 100
Contrast: 100
Grain Type: Regular

Don't forget to choose the appropriate fill
and THEN use the Grain filter!



MULTIMEDIA

OLYMPIAN HIGH SCHOOL

11. Again, copy the circle by hitting Ctrl + C and paste it in front by hitting Ctrl + F. Now, select the new circle and change its dimensions by using the toolbar on the top.

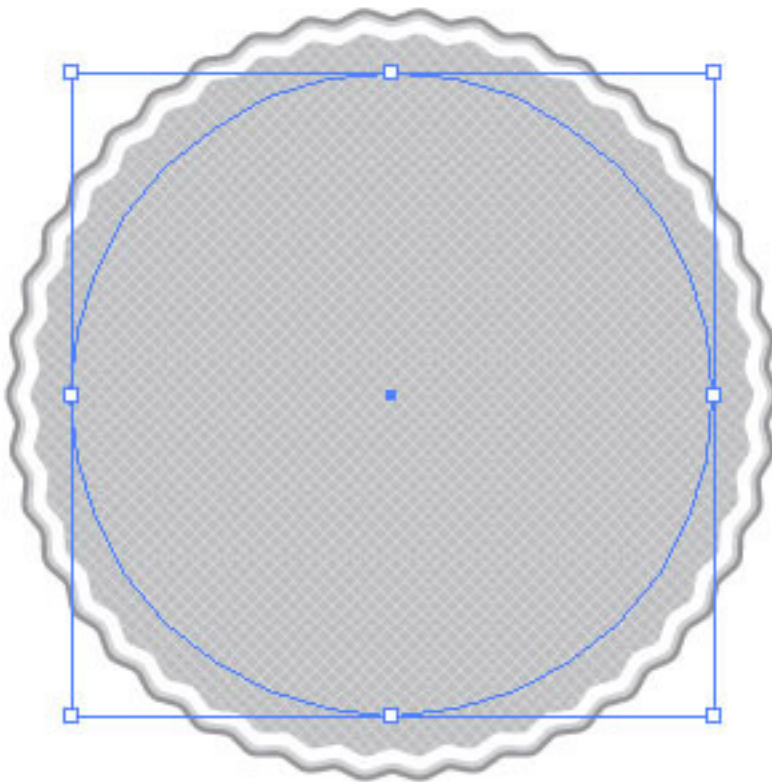
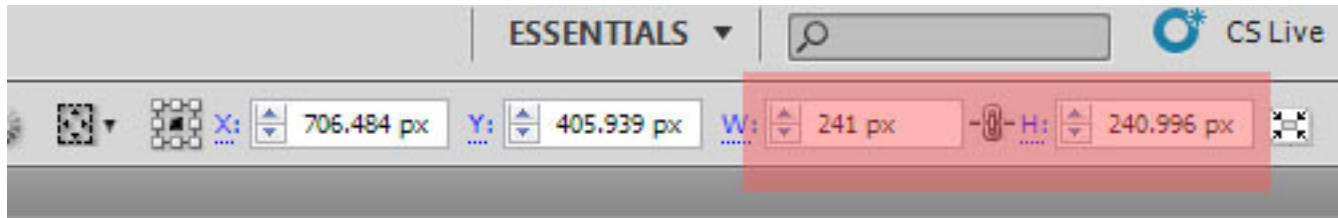

Ctrl + C to copy
and **Ctrl + F** to paste.
For Windows.

Cmd + C to copy
and **Cmd + F** to paste.
For Macs.



MULTIMEDIA

OLYMPIAN HIGH SCHOOL

12. With the Appearance Panel, add a new stroke to this new circle. Also change the existing bottom fill to values shown in the image.

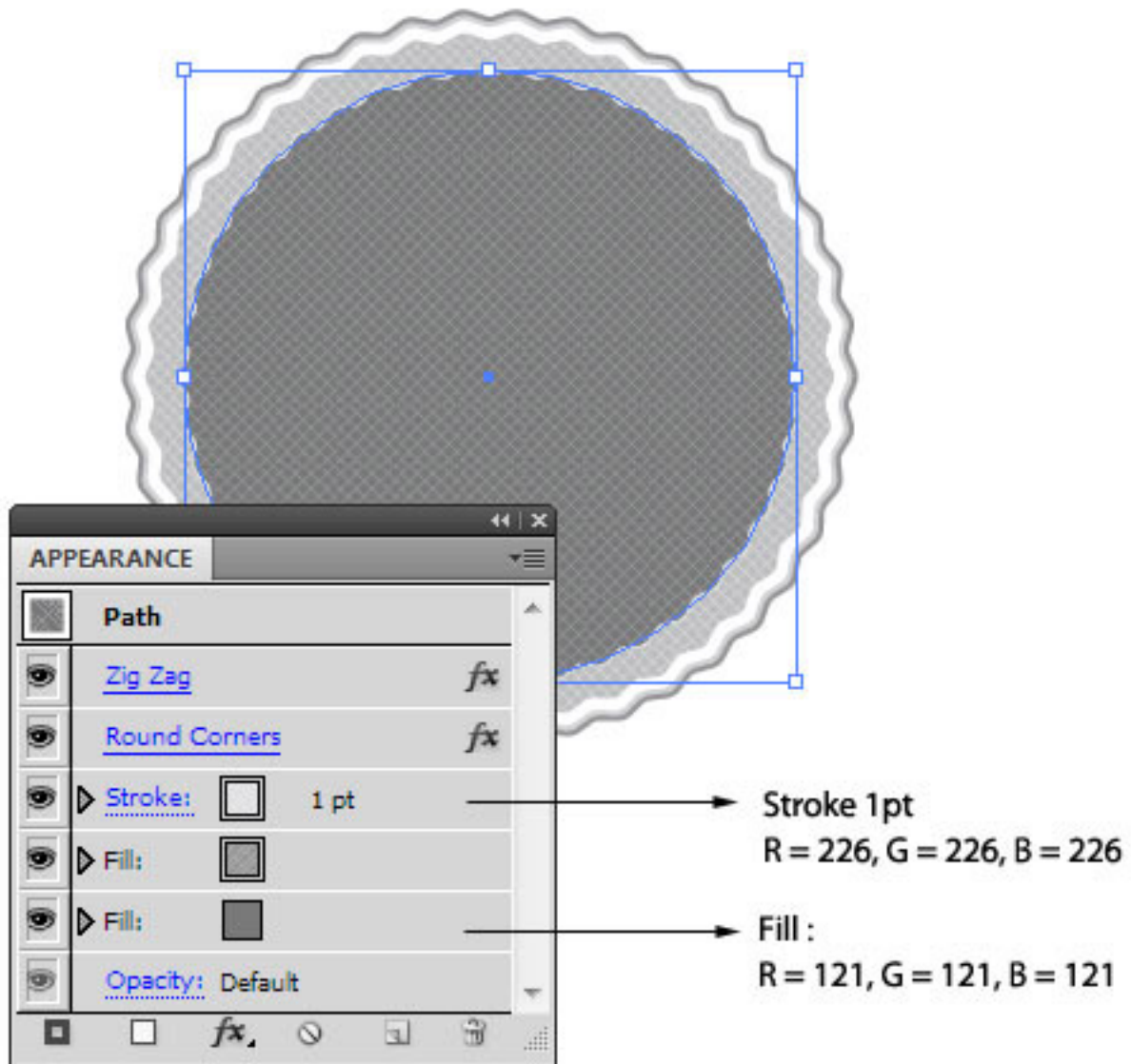



MULTIMEDIA

OLYMPIAN HIGH SCHOOL

13. Now, click on the texture fill. Let's modify it. Again, just edit it (don't add a new fill). Navigate to "Swatch Libraries Menu" as mentioned before. From there, go to Patterns > Decorative > Decorative_Geometric1 and select "Crosses Color". Change the opacity from 48% to 10% and delete the grain effect.

The image shows a circular graphic with a dark grey textured fill and a white wavy border. The graphic is selected with a blue bounding box. Below the graphic, the 'APPEARANCE' panel is open, showing the following settings:

- Path
- Zig Zag (fx)
- Round Corners (fx)
- Stroke: 1 pt
- Fill: [Pattern Swatch]
- Opacity: 10% Overlay
- Fill: [Solid Grey]

Below the Appearance panel, the 'DECORATIVE_GEOMETRIC 1' swatch library is open, showing a grid of various pattern swatches. An arrow points from the 'Crosses Color' swatch in the library to the 'Fill' property in the Appearance panel.

Text annotations with arrows point to the graphic and the swatch library:

- Delete "Grain"
Modify Opacity
to 10% on Overlay
- Crosses Color**
Patterns > Decorative
> Decorative_Geometric1



MULTIMEDIA

OLYMPIAN HIGH SCHOOL

14. Copy the new circle again, paste it, and change the dimensions of the latest circle again by using the toolbar on top.

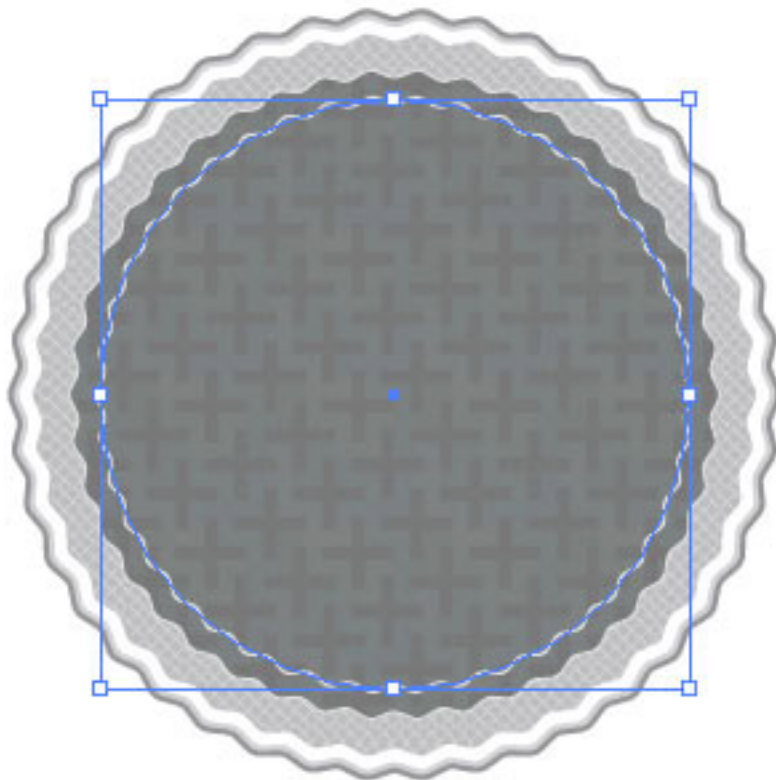
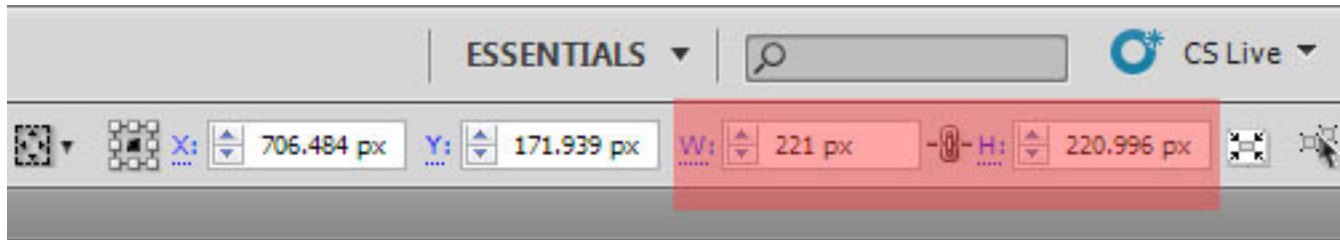

Ctrl + C to copy
and Ctrl + F to paste.
For Windows.

Cmd + C to copy
and Cmd + F to paste.
For Macs.



MULTIMEDIA

OLYMPIAN HIGH SCHOOL

15. Using the Appearance Panel, edit the stroke and the base fill. And yet again edit the texture fill to “Diagonal Lines” from Patterns > Basic Graphics > Basic Graphics_Textures and set the opacity to 34%. Change the “Overlay” to “Normal”.

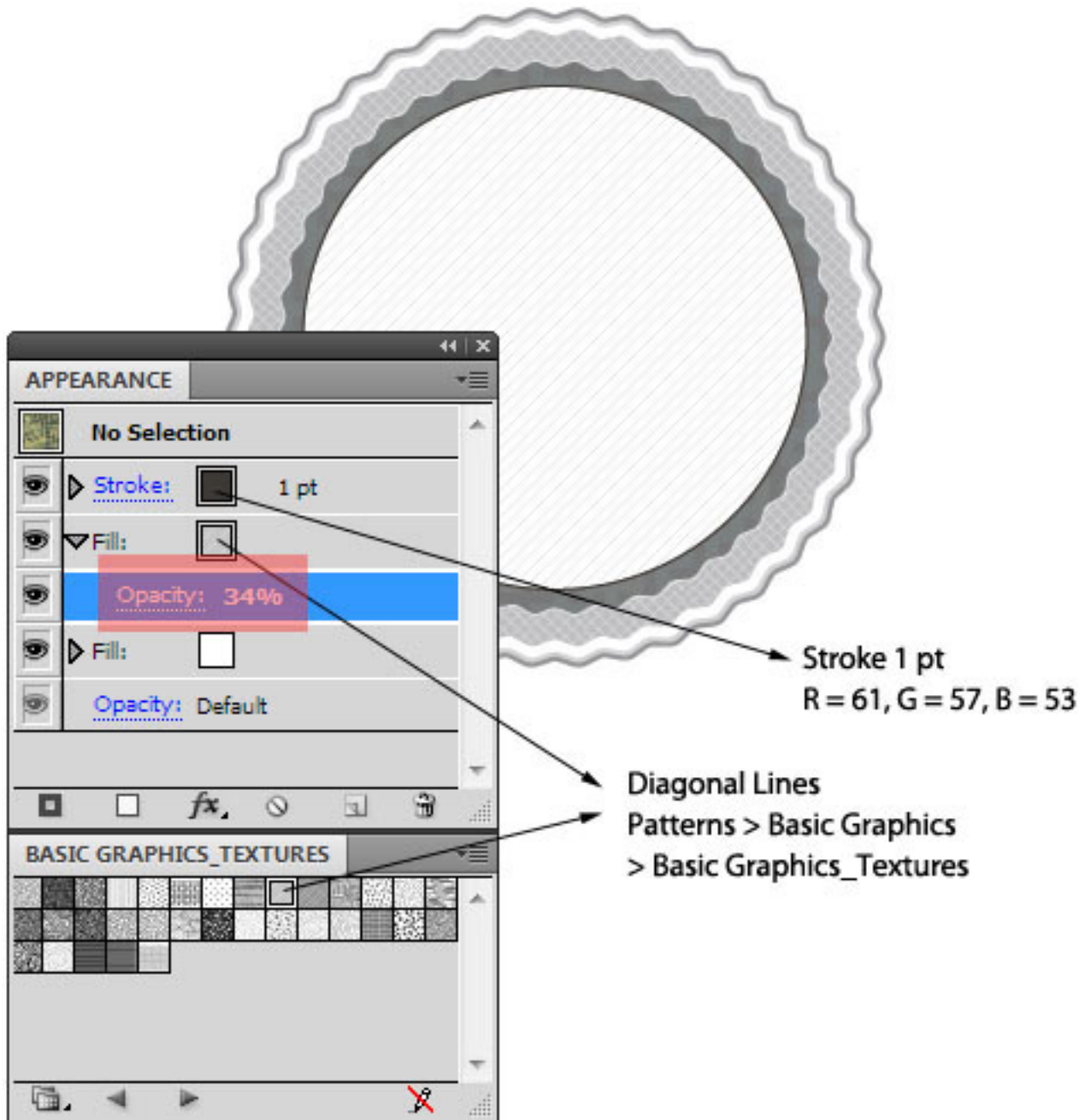



MULTIMEDIA

OLYMPIAN HIGH SCHOOL

16. Copy and paste the latest circle. Adjust the dimensions so that they are less than the previous circle by a small margin. In the Appearance Panel, delete everything except the "Stroke" and adjust it accordingly as shown in the image. This trick creates a cool "ring of dots".

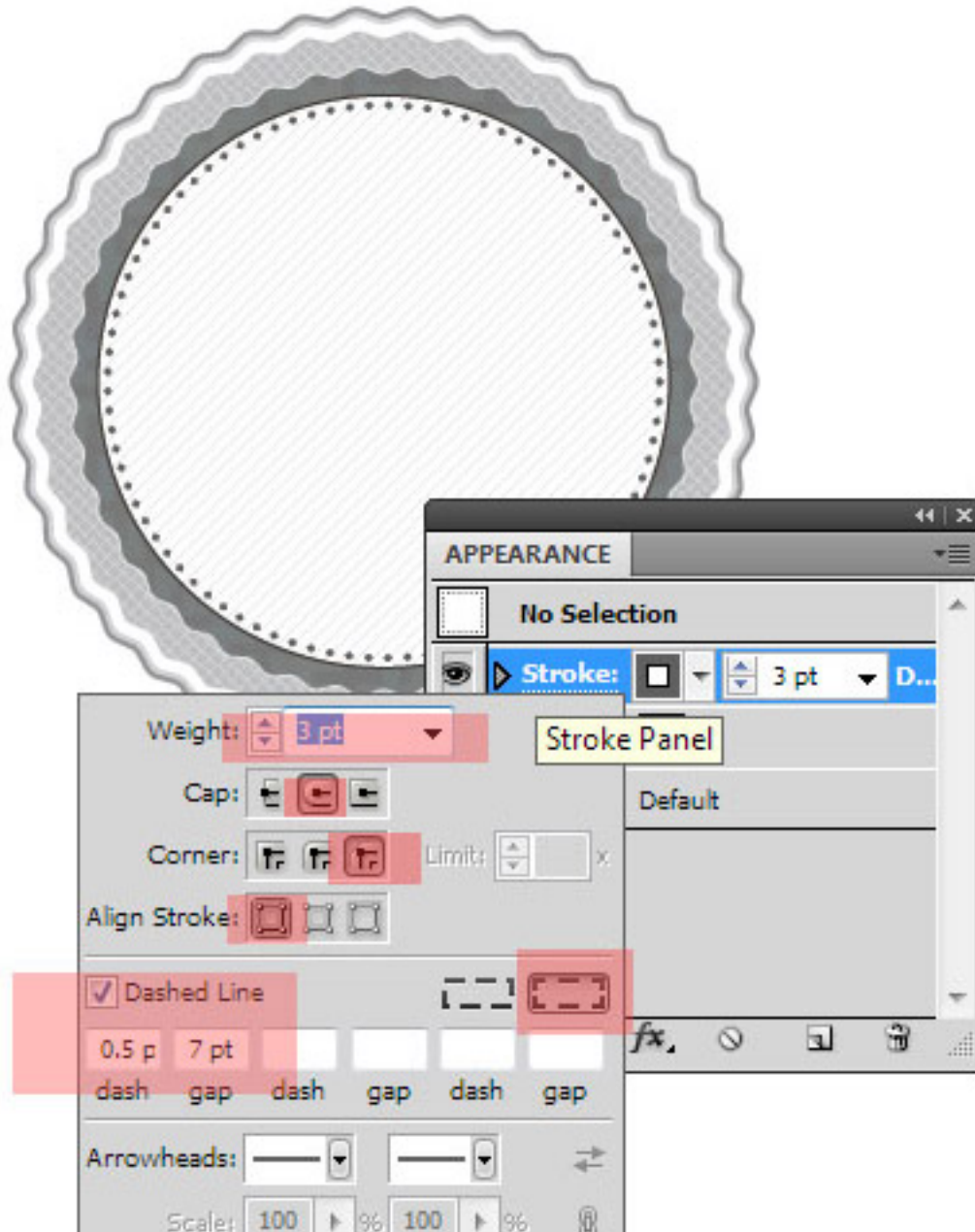

17. The base of our badge is done, let's move on to add features to its face. Let's start off by adding some text. Using the Type Tool (T) click anywhere on the artboard and type in anything that fancies you. I've typed in "League". Adjust the Font, the Font style and the Font size accordingly as shown in the image. Change the Fill, if you wish.

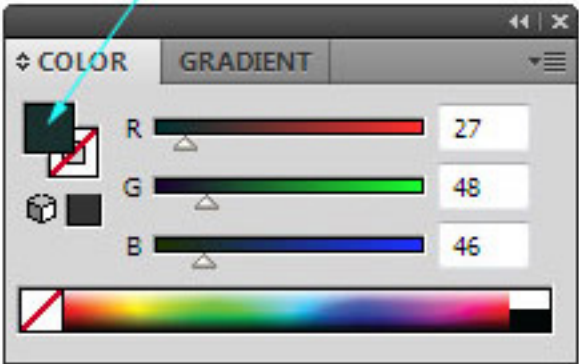
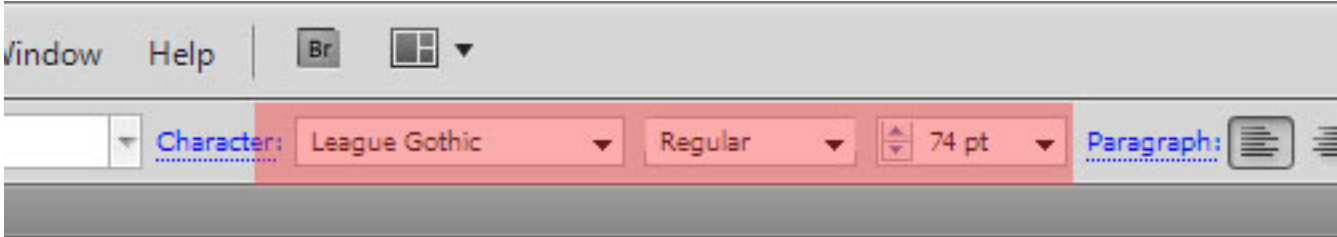



MULTIMEDIA

OLYMPIAN HIGH SCHOOL

18. With the text selected go to Effect > Warp > Arc Upper and set in the values as shown in the image. We are warping the text so that it fits nicely in the circular structure of the badge. This is editable, so even after warping you can easily edit the text.

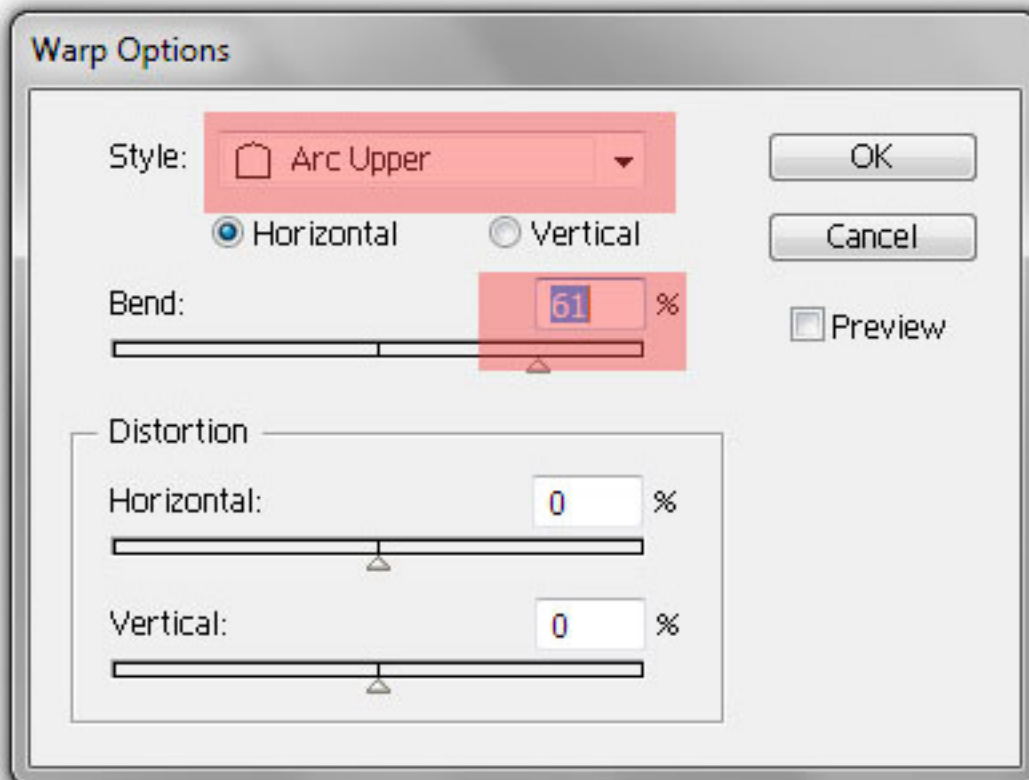



MULTIMEDIA

OLYMPIAN HIGH SCHOOL

19. Let's add a good drop shadow to this text so as to make it look 3D. With the text selected, go to Effect > Stylize > Drop Shadow and set in the values as shown in the image.

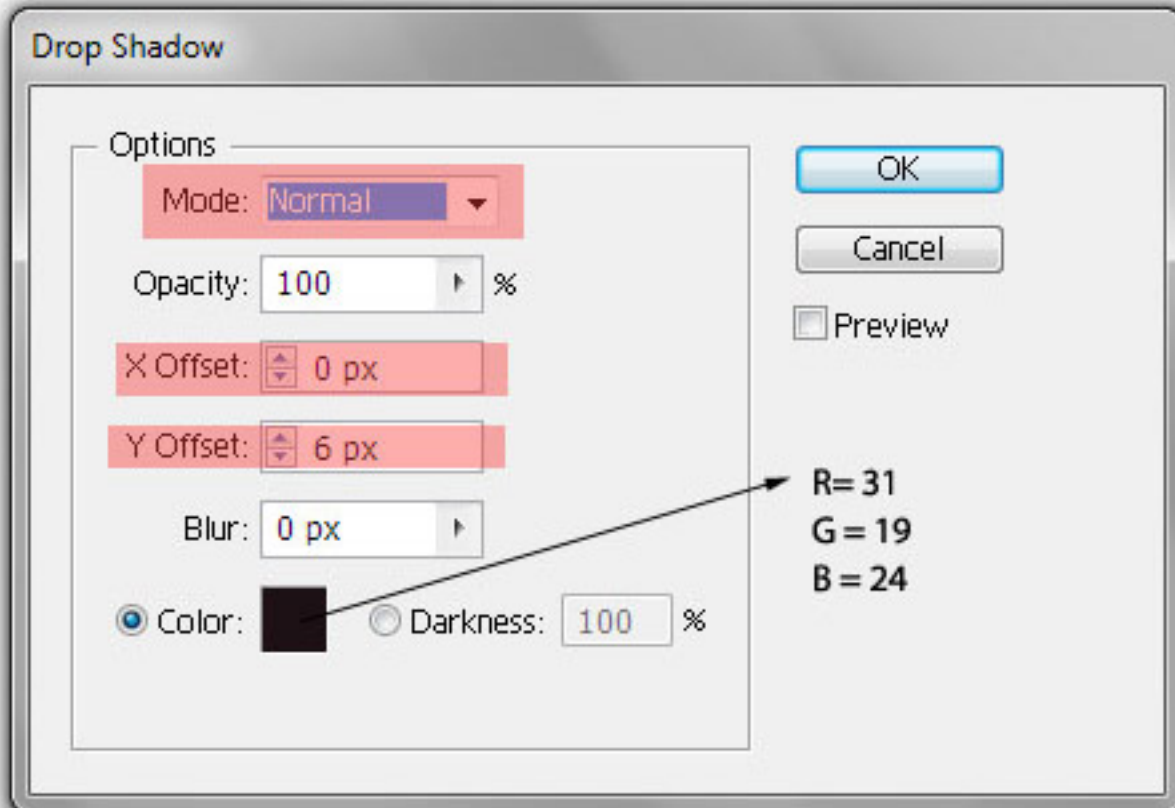

20. Now put this text on the badge and align it as shown in the image. One neat trick by using Shift + Arrow keys to nudge the text by 10px. You can also select both the circle and the text by holding down Shift and clicking on both these elements. Then, using tools on the top, click on "Horizontal Align Center" to horizontally align the text centrally in relation with the circle.

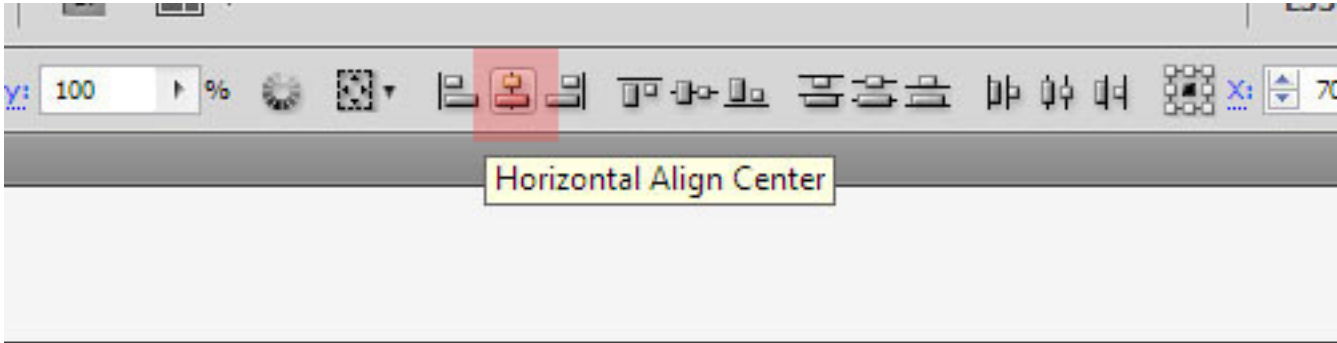



21. Let's move on to add some decorative elements on our badge. Start off by creating a star using Star Tool. Click on the Star Tool and drag out a star onto the Artboard. Hold down Shift to get a proportionate star and use the arrow keys to adjust how many points you wish to have. Duplicate this star (by clicking on it and then dragging it while holding Alt). Using the Direct Selection Tool (A) select the top point of the duplicated star and nudge it using Shift + Up arrow to nudge it in measures on 10px upwards. I've nudged it 70px.

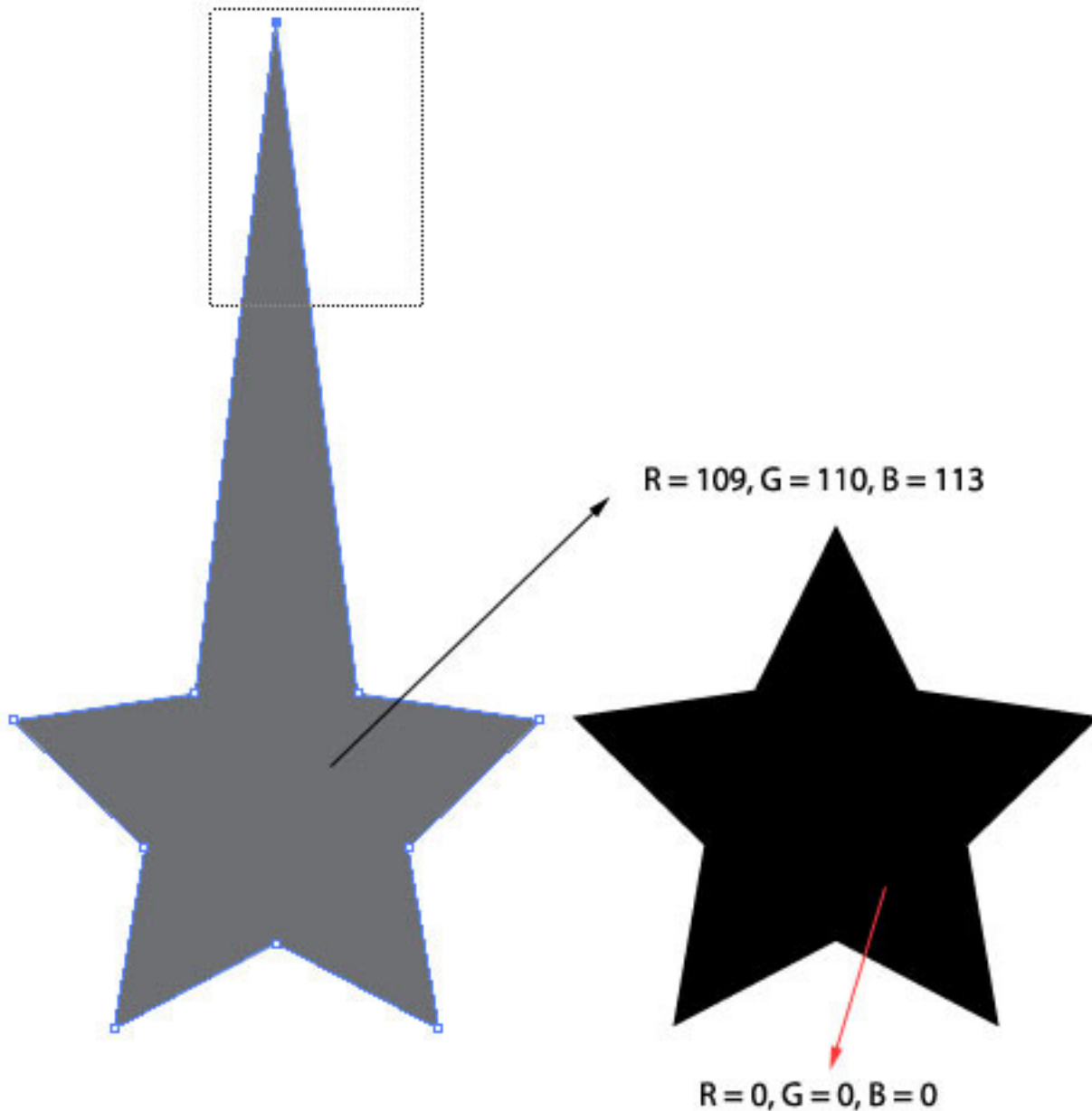



22. Again duplicate the duplicated star and the turn it upside down by selecting it and going to Object > Transform > Reflect, choose "Horizontal" and click OK.

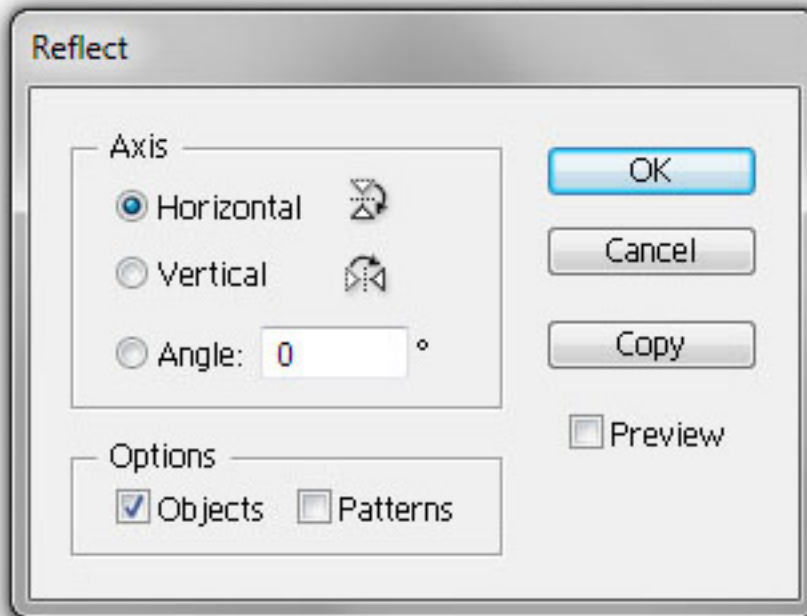
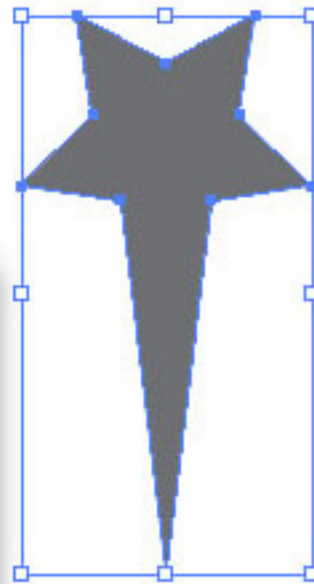



23. Align them as shown (Smart Guides will show you where their common centres are). Also you might have to change the stacking order so as to have the original star on top on the other stars. Use **Ctrl + [** to push an element down and **Ctrl +]** to pull an element up.



Align them as shown.

Use **Ctrl +]** or **Ctrl + [** to adjust the stacking order of elements.

Cmd +] or **Cmd + [** for mac fellas.

But, since there are a gazillion elements on the artboard, use **Shift + Ctrl + [** or **Shift + Ctrl +]**

Shift + Ctrl + [makes the selected element the bottommost element on the artboard where as **Shift + Ctrl +]** makes the selected element the topmost element on the artboard.

24. Make two copies of these stars and align them with the badge as shown in the image. Scale them accordingly as you wish.



Align as shown.

25. Draw some basic rectangular shapes using the Rectangle Tool (M) and make two copies of this. Use the image below for reference.



Draw some basic rectangular shapes and make two copies.

26. Align these to the badge as shown. You will probably have to scale them. But, you can position them wherever you wish, however big you wish.



Align as shown.



MULTIMEDIA

OLYMPIAN HIGH SCHOOL

27. Add some extra text. I've added "of" with the font "Lobster 1.3" at 35pt. Also, I've applied a basic drop shadow (Effect > Stylize > Drop Shadow). Place them between the rectangles we made, Use the image for reference.



Font: Lobster 1.3, 35pt

Also, a very basic drop shadow is applied.



MULTIMEDIA

OLYMPIAN HIGH SCHOOL

28. Using the Pen Tool (P) and Rectangle Tool (M) draw some shapes as shown in the image below. For now, set their stroke to black and fill to white.

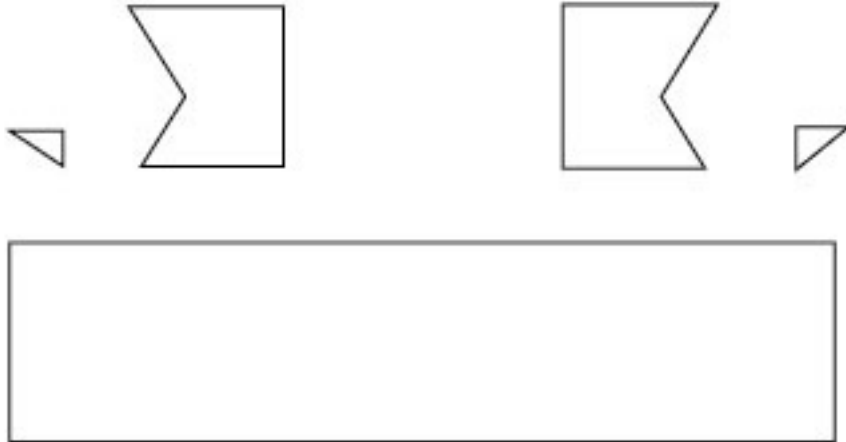

**With the Pen Tool, draw some basic shapes as shown.
And with the Rectangle Tool, just draw a rectangle. Any size works.**



MULTIMEDIA

OLYMPIAN HIGH SCHOOL

29. Graphic Styles in my opinion is the best feature in Illustrator. You can apply a set of styles to any shape, path or text which also remains editable. Like Layer Styles in Photoshop, but, better and more flexible. Now, let's create two graphic styles that we will apply to our shapes later. So, start off with any shape and modify its Fill and Stroke as shown in the image.

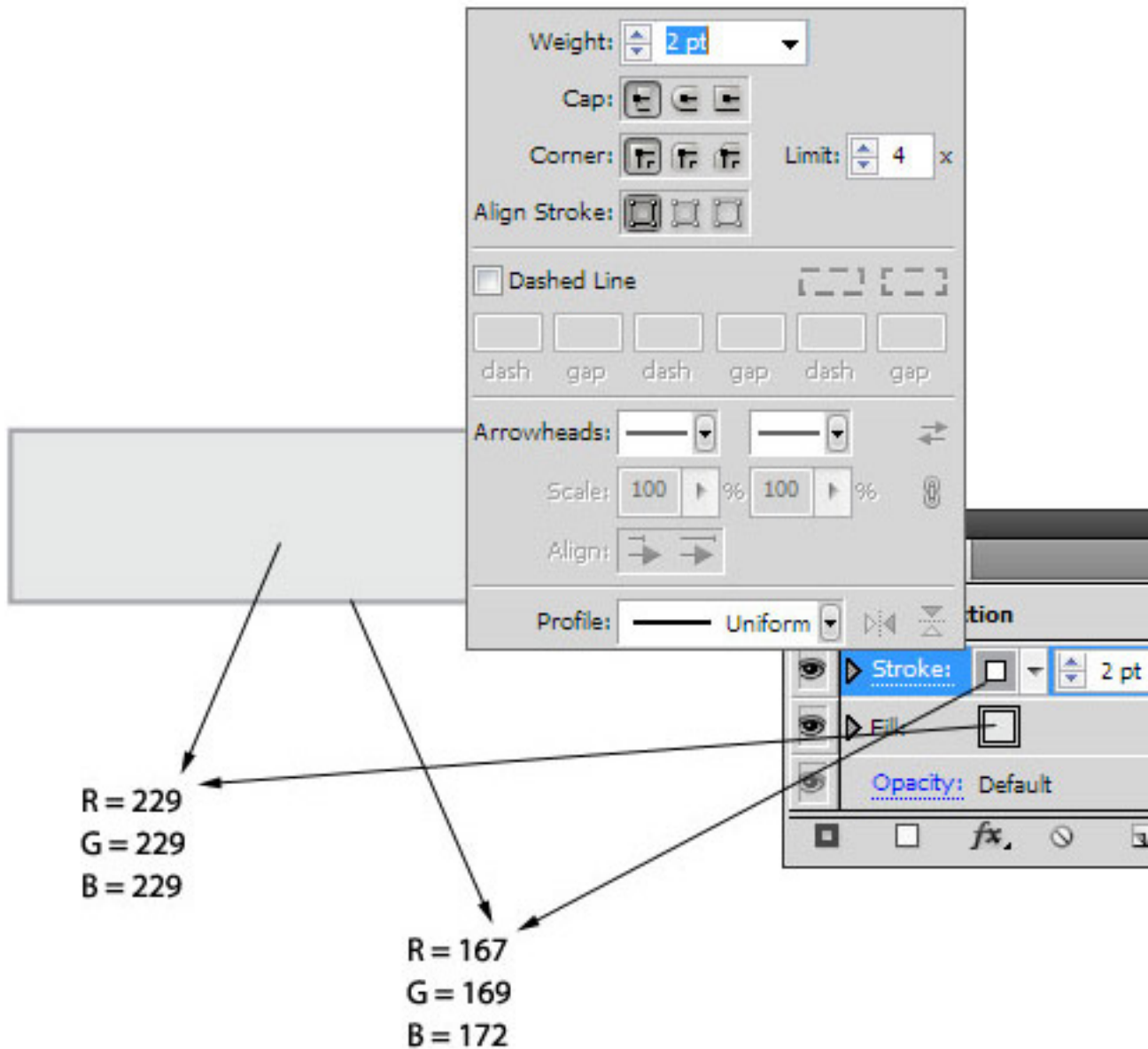



MULTIMEDIA

OLYMPIAN HIGH SCHOOL

30. Add a new fill to this shape and again navigate to “Swatch Libraries Menu” and go to Patterns > Basic Graphics > Basic Graphics_Textures and select “Diamond”. Set this fill on overlay.

Add a new fill.

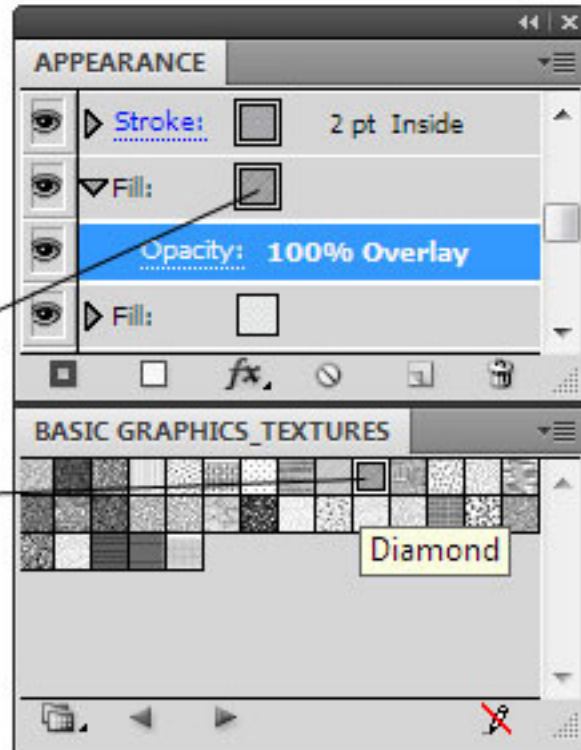
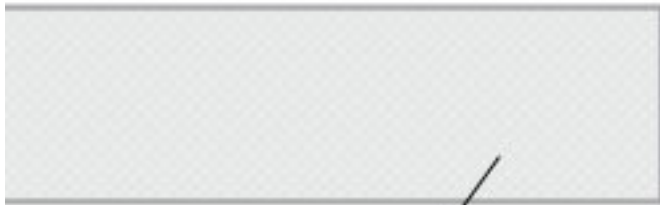

“Diamond”
Patterns >
Basic Graphics >
Basic Graphics_Textures

Set it on overlay.



31. Let's add some drop shadows to give it a 3D effect. So, select the shape and go to Effect > Stylize > Drop Shadow and hit in the following values.

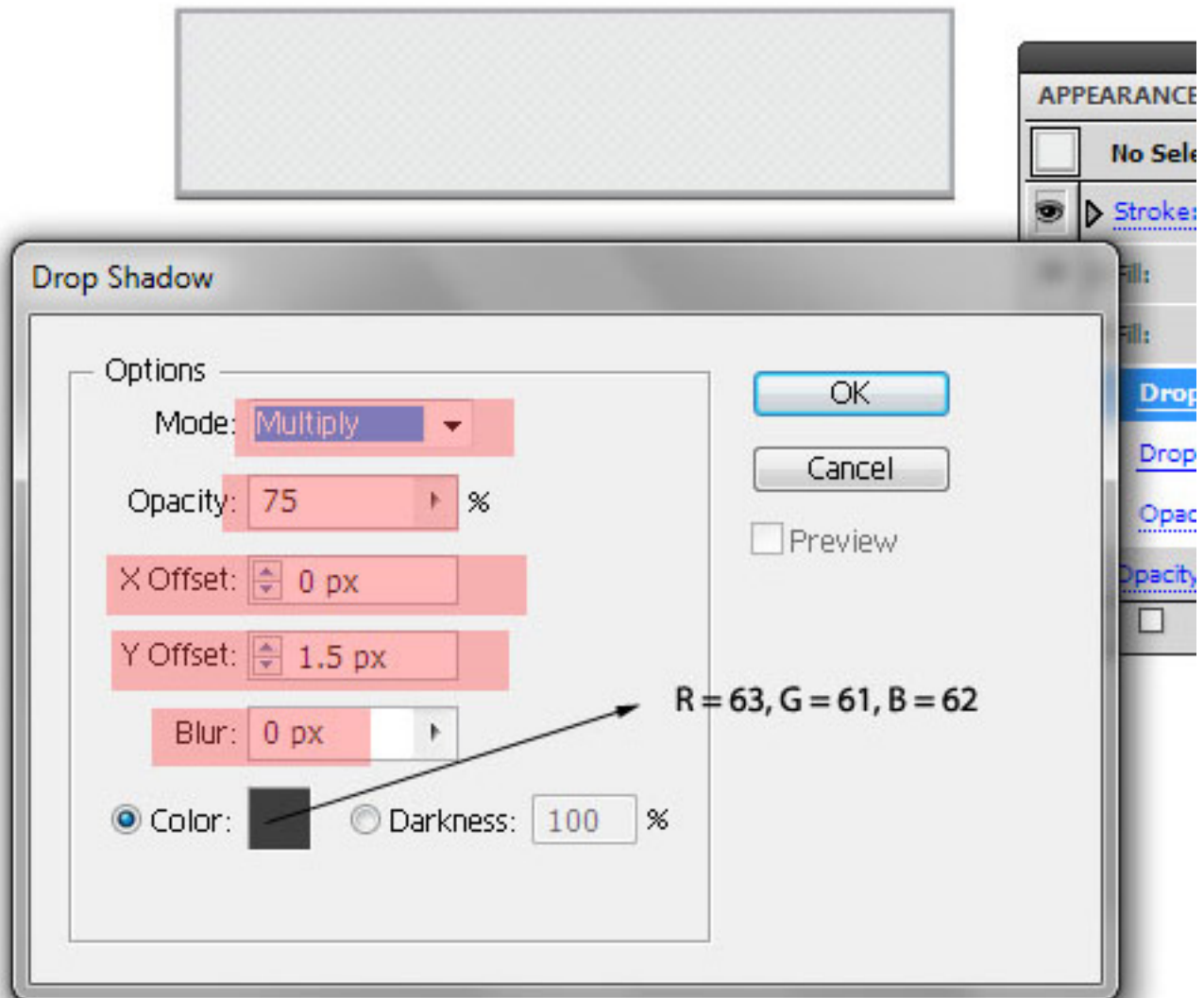



MULTIMEDIA

OLYMPIAN HIGH SCHOOL

32. We'll give it another drop shadow, so in the appearance panel, duplicate the Drop Shadow and edit it and just edit the color as shown in the image. Make sure that this drop shadow is below the previous drop shadow.

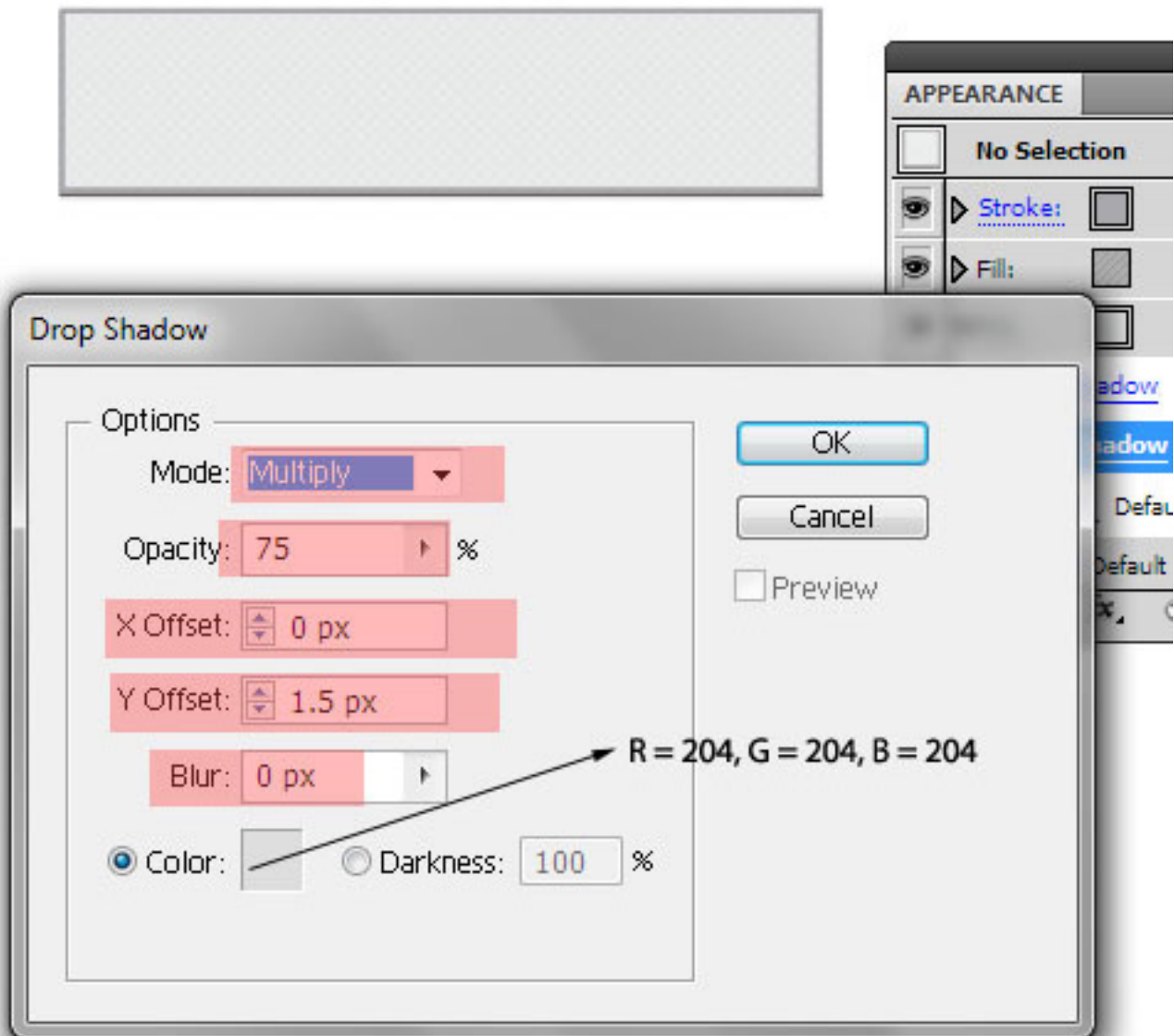



MULTIMEDIA

OLYMPIAN HIGH SCHOOL

33. Now open up your Graphic Styles Panel by going to Window > Graphic Styles or you can alternatively hit Shift + F5. Select the shape again, and click on the “New Graphic Style” button on the Graphic Styles Panel. Voila! There you have it, you can then apply this Graphic Style to any other shape/path/text.

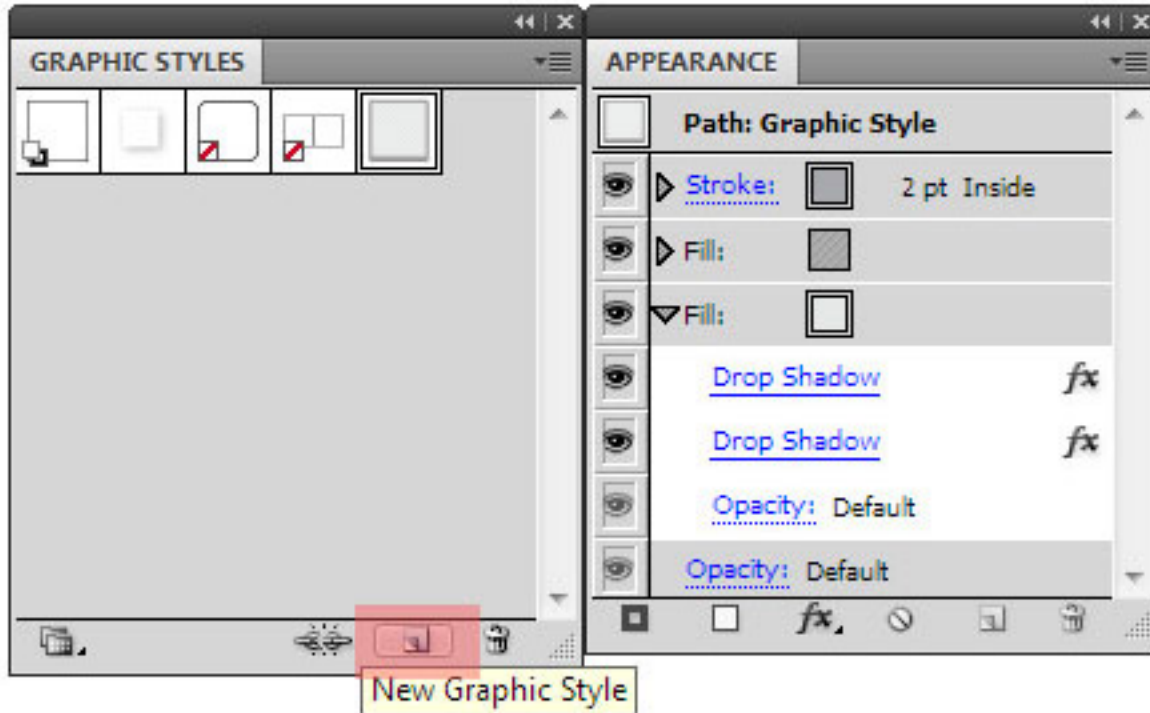

34. Now, onto our second graphic style. It is pretty similar, just delete the texture fill and change the base fill's color to white. Then again add this to the Graphic Styles Panel.

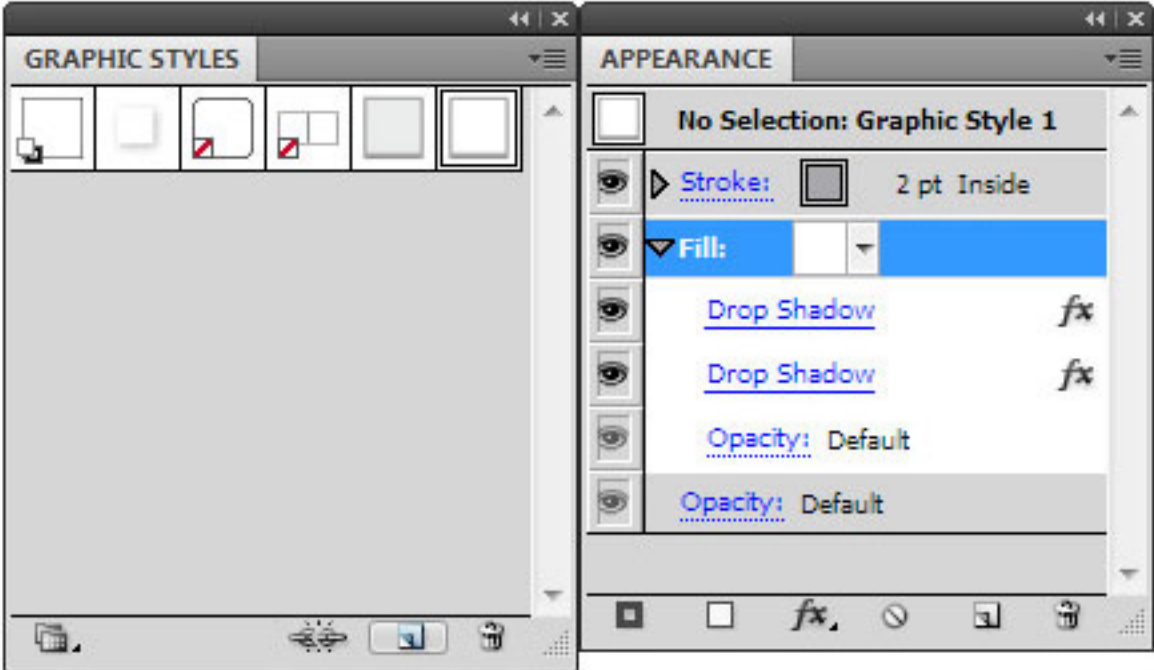

New Graphic Style



MULTIMEDIA

OLYMPIAN HIGH SCHOOL

35. Apply the first Graphic Style to the ribbon shapes we made. Don't apply it to the two mini triangles, just change their fill and delete their stroke. Now align all those shapes as shown in the image below.

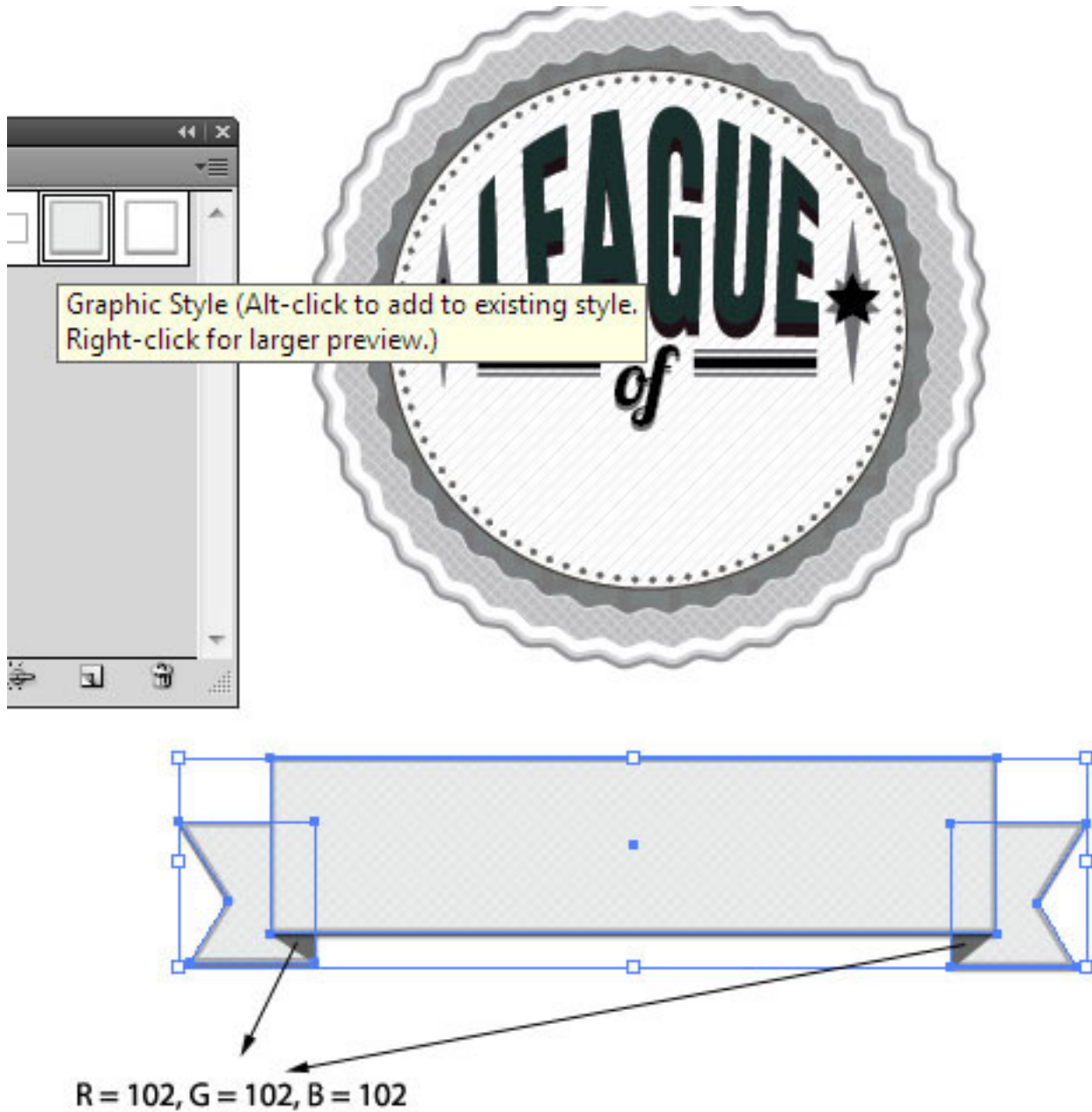



MULTIMEDIA

OLYMPIAN HIGH SCHOOL

36. Align the ribbon onto the badge as shown in the image below. To move around the whole ribbon and not just any single shape, just select all the elements of the ribbon and group them by hitting Ctrl + G. Also don't forget to change the stacking order of "of" so that it appears above the ribbon.



Align as shown, and change the stacking order of "of" to make it appear above the ribbon!



MULTIMEDIA

OLYMPIAN HIGH SCHOOL

37. Add text, I've used "ChunkFive" font here (I've used "Liberator" font in the final image.) Now, select the text and apply the second graphic style to this text. Align it over the ribbon as shown. We're done! or are we?



Add text, and then add the other graphic style.
Choose a thick font for the best font.

Fonts such as Liberator, ChunkFive (used here) work the best.



MULTIMEDIA

OLYMPIAN HIGH SCHOOL

38. Not yet! Let's add a finishing touch to the badge (which is not exactly needed). Import the badge over to Photoshop as a Vector Smart Object and then duplicate it. Select the top layer and go to Filter > Artistic > Colored Pencil and play around with the settings. Then, set this top layer on overlay and reduce the opacity to your need. And we're done!



And we're done! Isn't that distressed texture, amazing?